

## Proper Chain Lubrication

The ORSCO System uses compressed air as a catalyst to deliver lubricant with a velocity that penetrates deeper and more effectively than conventional drip and brush methods. A continuous thin film of lubricant is supplied to the exact point on the chain necessary for it to migrate between the pin and bushing as that is the primary wear point on a chain. The surface between the roller and bushing is also important and is lubricated in the same manner.

Each chain link travels through its cycle and returns to the spray nozzle where it is replenished with new and fresh lubricant. The low-pressure, "high-velocity" air forces the fluid/lubricant into the critical wear points and simultaneously provides a cleaning effect. This cleaning effect removes debris and contaminants from the chain. The process of continual lubrication is successful because the amounts applied are very small, and when set up correctly equals the rate of consumption for the application. The specific amount of lubricant required depends on chain length, speed and ambient temperature of the application. This approach has proven to reduce consumption rates significantly, often reducing overall consumption from 60% to 80%.

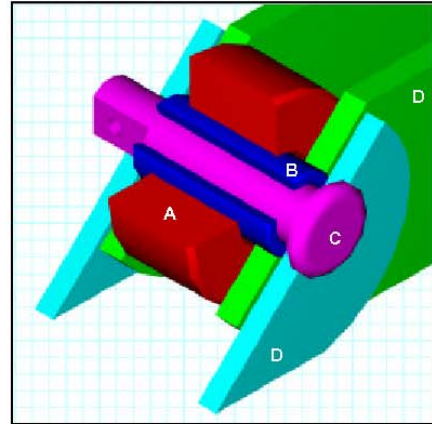

**Chain Cross Section**

**Chain Components:**

- A – Roller
- B – Bushing
- C – Pin
- D – Link Plates

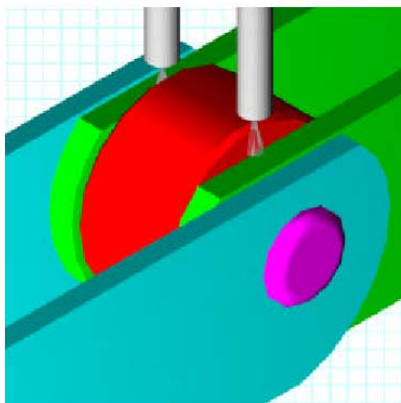
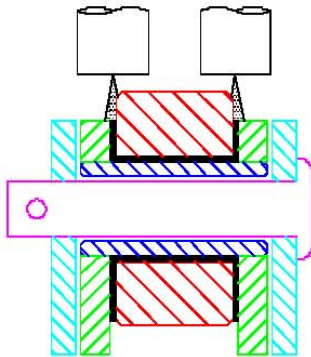

**Roller & Bushing Lubrication**

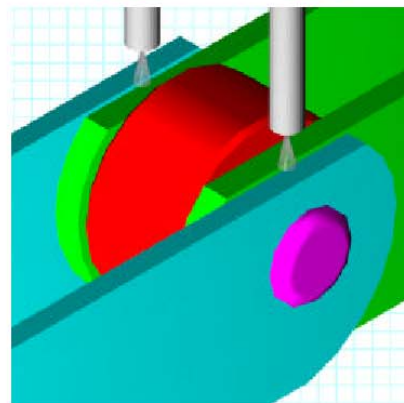
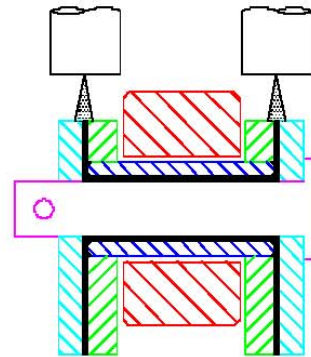

**Pin Lubrication**

## Roller Chain Application

Roller chains are manufactured in many sizes and materials for a great variety of applications and uses. To maximize the life of these many wear surfaces, it is essential to lubricate the pins, bushings, and any other sliding surface or rolling element. These illustrations provide a graphic tutorial as to the manner in which the ORSCO System approach succeeds in this endeavor.

Conventional lubrication systems cannot provide the accuracy of an ORSCO System. The illustration to the right shows how an ORSCO System delivers a thin film of oil to lubricate the bushing and roller, since the roller is load bearing in this example. Our ability to target this area successfully is a distinguishing feature of the ORSCO System. Our use of low pressure, "high-velocity" compressed air delivers small quantities in a penetrating manner. At the same time, our spray nozzles provide a cleaning effect to help remove any collection of debris or contamination that you chain may accumulate throughout your normal process or function.

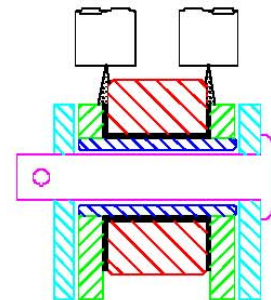
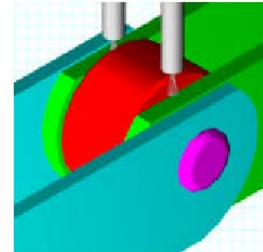

**Bushing & Roller  
Lubrication**

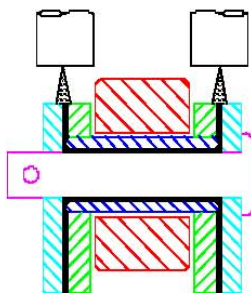
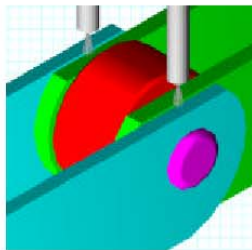

**Pin Lubrication**

Providing lubricant to the pins of the roller chain is also critical to the overall life of the chain. This reduces process down time and reduces the frequency of scheduled downtime for general maintenance. A properly lubricated chain also the power consumption (electricity) required to move this long connected mass. Depending on the specific orientation of your chain, it may require more than (2) points to properly support your needs.

Typical Applications Include:

- a) Flat-Top Conveyors
- b) Drag Conveyors
- c) Elevators
- d) Transfer Lines
- e) Drive Chains